

PROJECT DRAWING
 CHECKED BY:
 DRAWN BY:
 DATE:

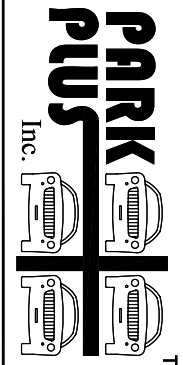

480 MAIN AVENUE UNIT 1
 WALLINGTON, NJ 07057
 TEL: (973) 574-8020
 FAX: (973) 574-8030
 www.parkplusinc.com
 email: info@parkplusinc.com

PROJECT LIFT SLIDING PARKING SYSTEM
 TECHNICAL SPECIFICATION
 SEMI-AUTOMATED PARKING SYSTEM

DRAWING DESCRIPTION
 MODEL LS3h

REVISIONS:
 △

THIS CONFIDENTIAL DOCUMENT IS THE PROPERTY OF PARK PLUS, INC. AND SHALL NOT BE GIVEN, COPIED OR REPRODUCED WITHOUT PRIOR WRITTEN CONSENT.

PARK PLUS Inc.™
 PARKING SYSTEMS

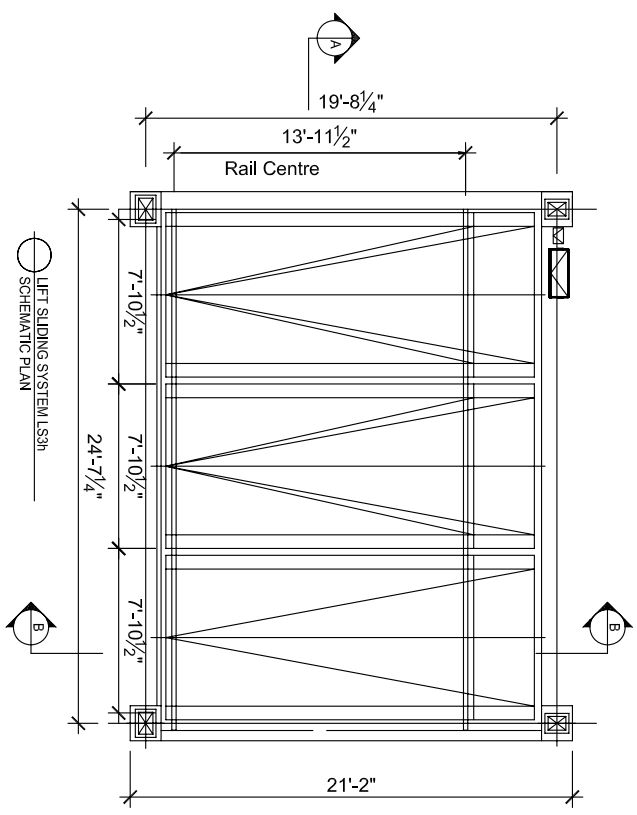

○ LIFT SLIDING SYSTEM LS3h
 SCHEMATIC PLAN

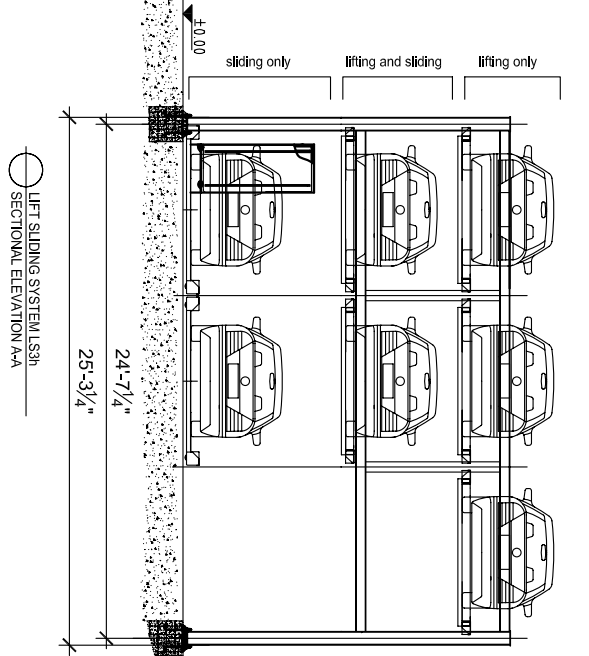

○ LIFT SLIDING SYSTEM LS3h
 SECTIONAL ELEVATION A-A

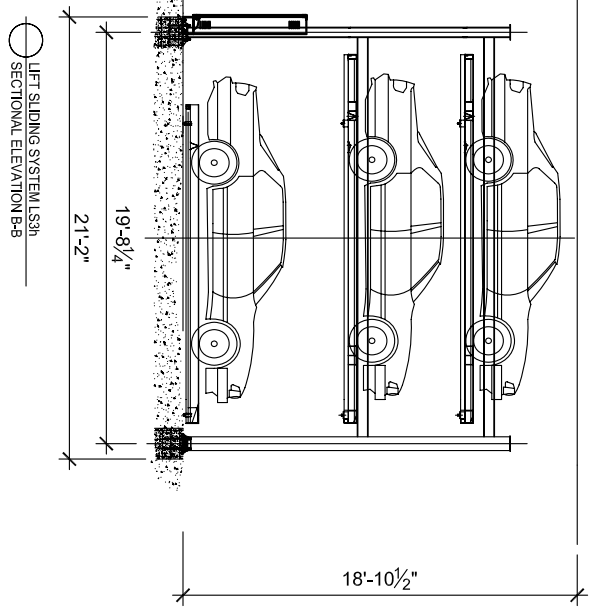

○ LIFT SLIDING SYSTEM LS3h
 SECTIONAL ELEVATION B-B