



*Leaders in high density vehicle storage systems*

**CORPORATE HEADQUARTERS**

31 Iron Horse Rd  
Oakland, NJ 07436  
Office: +1 (973) 574-8020  
Fax: +1 (973) 574-8030  
Toll Free: 1-800-966-5509

**SERVICE & OPERATIONS DEPARTMENT**

480 Main Ave, Unit 1  
Wallington, NJ 07057  
Office: +1 (973) 574-8020  
Fax: +1 (973) 574-8030  
Toll Free: 1-800-966-5509

**PARK PLUS FLORIDA, INC.**

1835 East Hallandale Beach Blvd  
Suite 439  
Hallandale, FL 33009  
Office: +1 (954) 374-8434  
Fax: +1 (953) 374-8860

**PARK PLUS CHICAGO**

P.O. Box 59505  
Schaumburg, IL 60159  
Office: +1 (847) 612-4038  
Fax: +1 (847) 592-6789

[www.parkplusinc.com](http://www.parkplusinc.com)

email: [info@parkplusinc.com](mailto:info@parkplusinc.com)



**AUTOMATED SYSTEMS**

## Lift Sliding System

Semi-Automatic vehicle storage system

The Lift Sliding parking system maneuvers stacked vehicles on platforms in horizontal and vertical motions in order to lower vehicles to grade position through a Programmable Logic Control system.

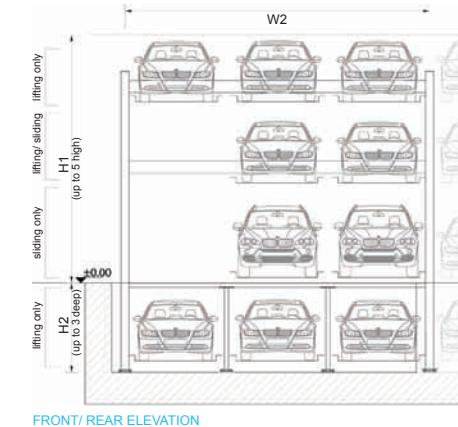
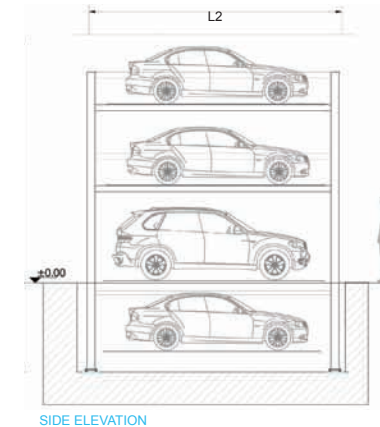
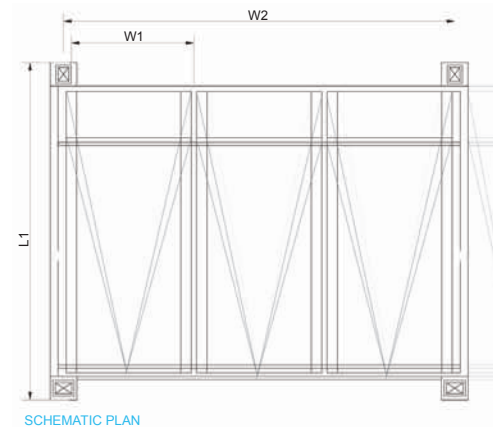

EQUIPMENT DIMENSIONS (Lift Sliding system)		
Length	L1	19' - 8"
Width	W1	7' - 11" to 8' - 3" (Per platform)
	W2	Variable
Height	H1	Variable
Pit Requirement	H2	Variable
<b>CERTIFIED LIFTING CAPACITY</b>	5200 lbs/ Platform	
<b>LIFTING SPEED</b>	13 - 26 ft/ min	
<b>SLIDING SPEED</b>	26 ft/ min	
<b>MAXIMUM STACKING</b>	5 Above Grade/ 3 Below Grade	
<b>OPERATION</b>	Automatic	
<b>CONTROL</b>	Key pad/ remote devices	
<b>ELECTRICAL POWER</b>	3-phase/ 60 Hz	

## Parking Tower System

Automatic vehicle storage system

The Parking Tower System consists of 2 vertical vehicle stacks separated by a vertical transfer shaft. This vehicle storage and retrieval system utilizes parking pallets or platforms that are placed into position on a storage racking system.

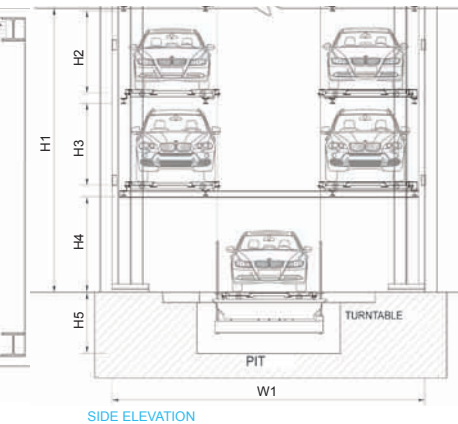
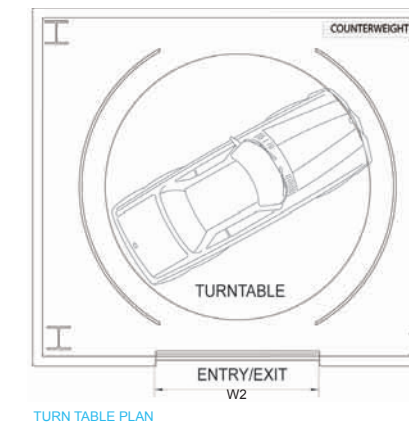
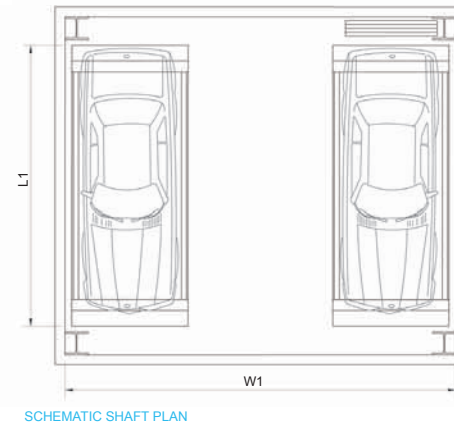

EQUIPMENT DIMENSIONS (Parking Tower system)		
Length	L1	18'
Width	W1	25' - 1/2"
	W2	10' - 6" (entry/ exit)
Height	H1	Variable
	H2/ H3	6' - 7" (platform)
	H4	6' - 8" to 7' - 8" (minimum clearance)
	H5	4' - 11" (pit depth)
<b>CERTIFIED LIFTING CAPACITY</b>	6000 lbs/ Platform	
<b>MAXIMUM STACKING</b>	25 Above Grade	
<b>OPERATION</b>	Automatic	
<b>CONTROL</b>	Key pad/ remote devices	
<b>ELECTRICAL POWER</b>	3-phase/ 50 Hz	

## Auto Park

Fully Automatic vehicle storage system

The Auto Park system is designed for maximum efficiency and space utilization for high density parking. It features a virtually unlimited stacking capability and a fully integrated storage and retrieval functionality. Each design layout is custom suited for each project.

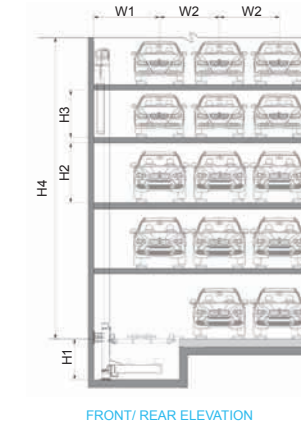
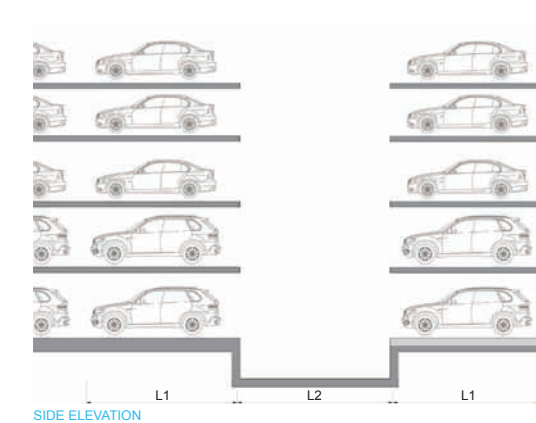
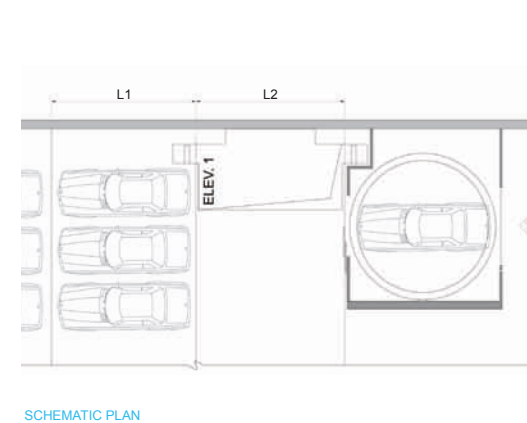

EQUIPMENT DIMENSIONS (Auto Park)		
Length	L1	18' - 6" (Stall)
	L2	19' - 1" (Transfer Aisle)
Width	W1	8' - 1" (First center line)
	W2	7' - 4" (Typical center line)
Height	H1	5' - 0" (Minimum Pit clearance)
	H2	7' - 4" (Min SUV clearance requirement)
	H3	5' - 10" (Min Sedan clearance requirement)
<b>CERTIFIED LIFTING CAPACITY</b>	6000 lbs/ Platform	
<b>MAXIMUM STACKING</b>	Variable	
<b>OPERATION</b>	Automatic	
<b>CONTROL</b>	Key pad/ Remote device	
<b>ELECTRICAL POWER</b>	3-phase/ 60 Hz	

## Mini System

Mechanical vehicle storage system with pit

This system includes the use of an in-ground pit in order to retrieve stacked vehicles without the need for removing any other vehicles within the system, therefore this type of system can be considered as "self-parking". This product is available as a 2 vehicle stacking unit or as a 3 vehicle stacking unit.

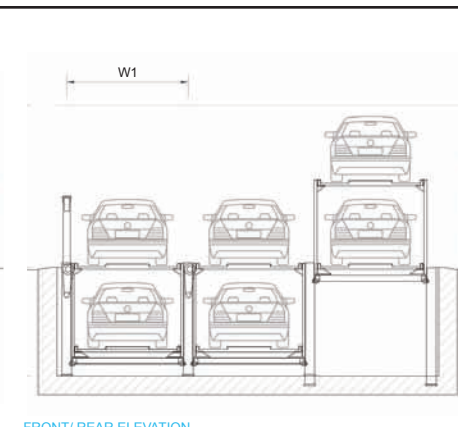
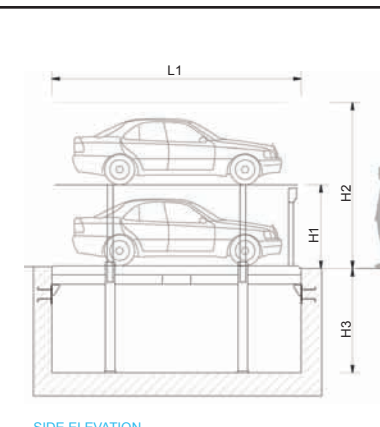
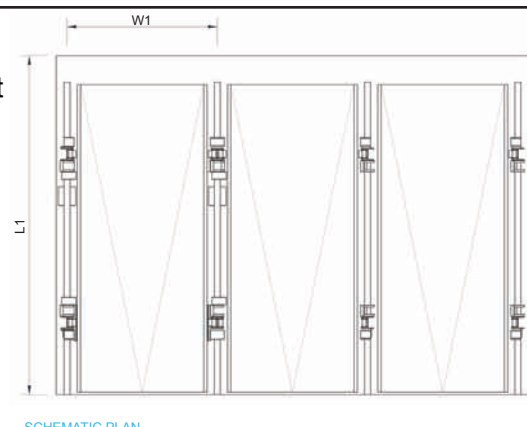

EQUIPMENT DIMENSIONS (Mini System)		
Length	L1	17' - 3"
Width	W1	8' - 2 1/2" (Center to center)
Height	H1	5' - 9" to 7' - 8" (platform height)
Clearance requirement	H2	11' - 6" to 17' - 3"
	H3	7' - 3" (below grade)
<b>CERTIFIED LIFTING CAPACITY</b>	6000 lbs/ Platform	
<b>LIFTING SPEED</b>	8 ft/ min	
<b>MAXIMUM STACKING</b>	3 Vehicles	
<b>OPERATION</b>	Electrical	
<b>CONTROL</b>	Push button	
<b>ELECTRICAL POWER</b>	3-phase/ 60 Hz	