

minimum clearance 10'-6" to 14'-0"

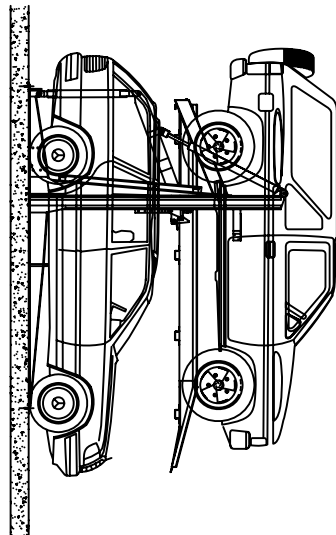

ALL UNITS AVAILABLE AS SINGLE STANDING OR SHARED WITH COMMON LEG

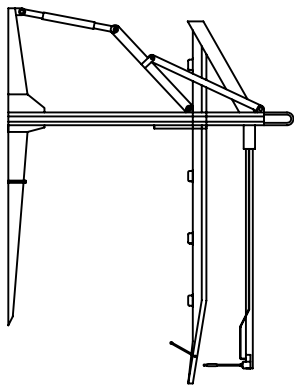
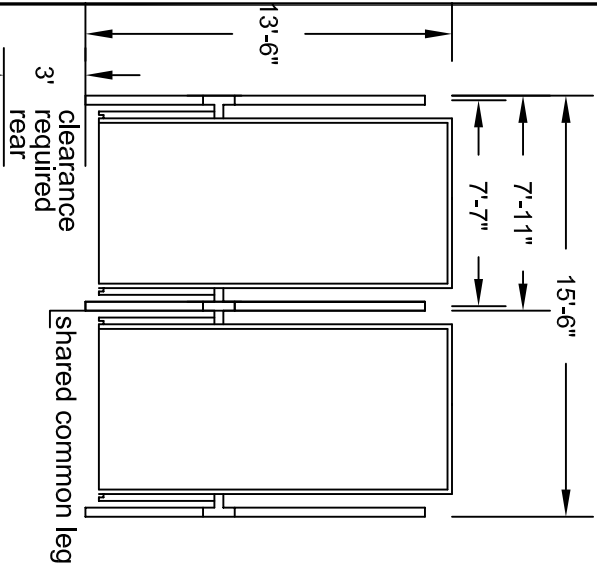

DP003 L-11 SCHEMATIC PLAN

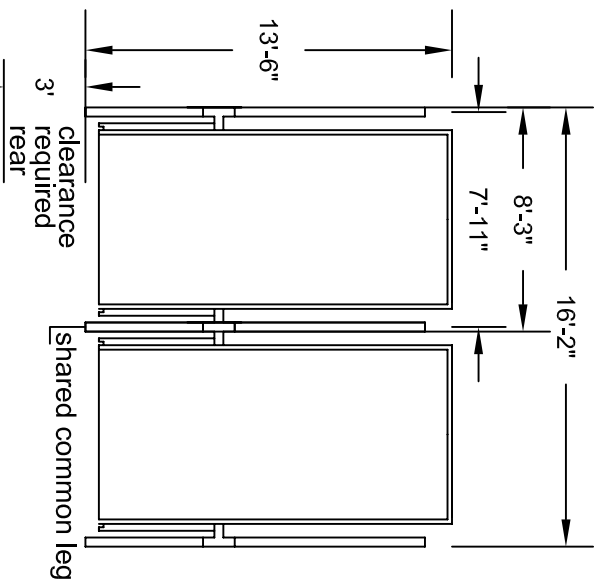

DP003 L-12 SCHEMATIC PLAN

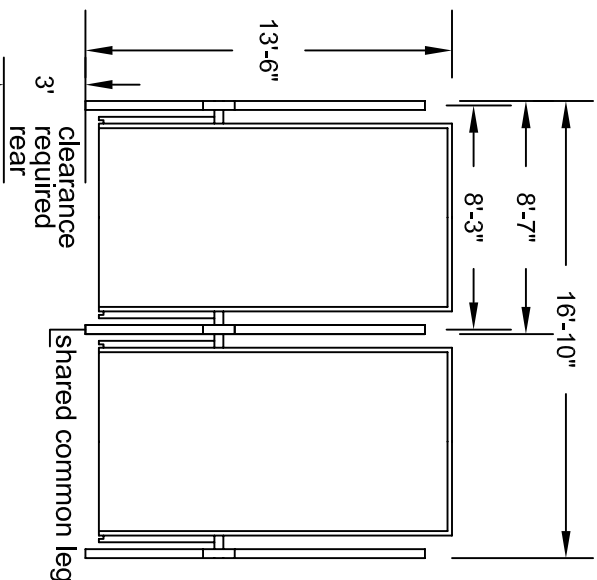

DP003 L-13 SCHEMATIC PLAN

PARK PLUS Inc.™

PARKING SYSTEMS

THIS CONFIDENTIAL DOCUMENT IS THE PROPERTY OF PARK PLUS, INC. AND SHALL NOT BE GIVEN, COPIED OR REPRODUCED WITHOUT PRIOR WRITTEN CONSENT.

DATE: \_\_\_\_\_  
DRAWN BY: \_\_\_\_\_  
CHECKED BY: \_\_\_\_\_  
PROJECT DRAWING

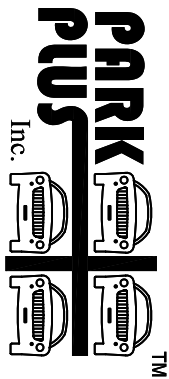

480 MAIN AVENUE UNIT 1  
WALLINGTON, NJ 07057  
TEL: (973) 574-8020  
FAX: (973) 574-8030  
www.parkplusinc.com  
email: info@parkplusinc.com

PROJECT DOUBLE PARKING SYSTEMS  
TECHNICAL SPECIFICATION

DRAWING DESCRIPTION

DP003 TYPES L11 L12 L13

DRAWING NOT TO SCALE

REVISIONS:  
△